



HB 8874
HB 8874V

Oscillating cast cutting saw HEBU Oscillo-Saw GOLD II Accu

Content

- 1 Scope of delivery 17
- 2 Safety remarks 17
- 3 Scope 18
 - 3.1 Inteded Use 18
 - 3.2 Contraindications 18
- 4 Accumulator 18
- 5 Mounting / exchanging the saw blade 19
 - 5.1 Releasing the retaining screw / removing the old saw blade 19
 - 5.2 Inserting the new saw blade 20
- 6 Operation 21
 - 6.1 Opening plaster casts 21
- 7 Cleaning and maintenance 22
- 8 Accessories 23
- 9 Spare Parts 23
- 10 Servicing 24
 - 10.1 Saw head 24
 - 10.2 Saw motor 25
- 11 Warranty 26
- 12 Environmental protection 26
- 13 Specifications 26
- 14 Manufacturer and aftersales service address 26



**HEBU
Oscillo-
Saw
GOLD II
Accu**

1 Scope of delivery

HB 8874	HEBU oscillating cast cutting saw GOLD II Accu
HB 8876	Accumulator 5000 mAh
HB 8879	Quick Recharger
HB 8895-02	Circular saw blade, dia. 50 mm, x-bite
HB 8896-02	Circular saw blade, dia. 65 mm, x-bite
E 8894-01	2x fork wrenches
	Operating instructions

2 Safety remarks

Our products are exclusively intended for professional use by appropriately trained and qualified personnel and may only be acquired by them.

All safety remarks in these operating instructions are marked with the symbol **!**.

!	Before using the saw, carefully read through these operating instructions and the valid national occupational safety regulations and act accordingly. <i>Please keep these operating instructions for later reference and always include them if the device is sold or passed on to third parties.</i>
!	Application in accordance with the intended application: This device is intended for sawing open plaster casts.
!	Avoid mechanical overstressing of the device beyond the structural design, this can lead to breakage and loss of function!
!	Never rivet or screw signs or symbols onto the device, as this can render the protective insulation ineffective. We recommend using adhesive signs.
!	Only ever use original accessories.
!	Wear personal protective gear such as protective goggles, ear protectors and gloves.
!	The device must not be operated in areas at risk from explosion.
!	Any serious incident that has occurred in relation to the device should be reported to the manufacturer and the competent authority of the Member State in which the user and/or patient is established.

3 Scope

The use of oscillating plaster saws mainly takes place in orthopedics for plaster removal.

3.1 Inteded Use

A hand-held, power-driven (AC) product for cutting gypsum or synthetic material usually during the removal of a plaster cast. The proximal end (the handle) is usually cylindrical, while the distal end terminates in a round, crescent-shaped, or circular blade suitable for cutting plaster casting material. The leaves cut as an electric motor in the handle drives them (swinging). The cut is done by vibration rather than by sawing.

3.2 Contraindications

There are no known contraindications.

4 Accumulator

To take off the accumulator press the red coloured button to unlock it. At the same time pull the accumulator upwards off the saw, see fig. 1

To attach to accumulator, pull it from top onto the rails until your hear it snap in.

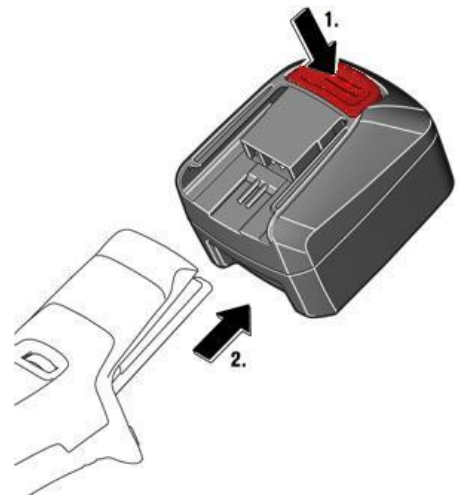

fig. 1 Removing the accumulator

Accumulator status

To check the charge status of the accumulator, press the red button located on the side of the accumulator, like in fig. 2. The real percentage of the battery charge condition is only indicated when the power tool motor is stopped.

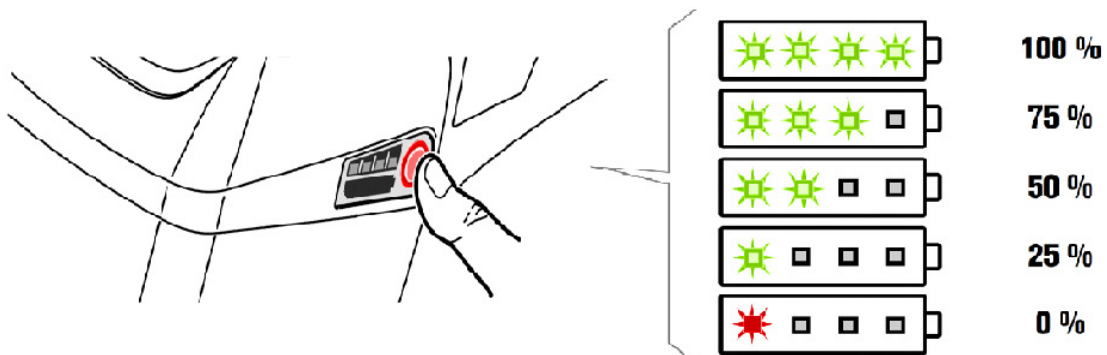

fig. 2 Accumulator status

LED indicator	Meaning	Activity
1 – 4 green LED	Percentage of charge condition	Operation
Continuous red light	Battery is almost empty	Charge battery
Red flashing light	Battery is not ready for operation	Bring the battery into the battery operating temperature range, then charge

The electronics automatically switch off the motor prior to the battery being deep discharged. Operate and charge the battery only within the **battery operating-temperature range of 0 °C – 45 °C (32 °F – 113 °F)**. At the beginning of the charging procedure, the battery temperature must be within the battery operating- temperature range.

5 Mounting / exchanging the saw blade



Danger of injury when unintentionally turned on. Remove accumulator before changing. Should it be necessary, use stable gloves so that you can not be injured by the saw blades. Only connect the accumulator when the saw is switched off.

5.1 Releasing the retaining screw / removing the old saw blade

1. Place the cast cutting saw on a stable underlay (table).
2. Apply one fork wrench at the drive shaft behind the saw blade, and the other one at the front at the retaining screw (see fig. 3).
3. Hold the rear wrench firmly and use it to fix the cast cutting saw.
4. Release the retaining screw using the front wrench.
5. Remove the retaining screw and the fixing ring. Ensure that you do not lose any components.
6. If applicable, remove the old saw blade.



fig. 3 Releasing the retaining screw

5.2 Inserting the new saw blade

1. Check that the female thread and saw blade support of the drive shaft are clean.
2. Position the new saw blade. *It makes no difference which side of the saw blade is facing inwards or outwards.*

Important! The notches in the saw blade must be positioned precisely flush on the spigots of the drive shaft.

3. Position the fixing ring. The notches in the fixing ring must always be pointing towards the saw (see fig. 4). These must also be positioned precisely on the spigots.
4. Screw the retaining screw in manually until hand tight.
5. Then tighten firmly using the fork wrench, as described above. The tightening torque is 6 - 7 Nm. Caution! Do not overtighten.

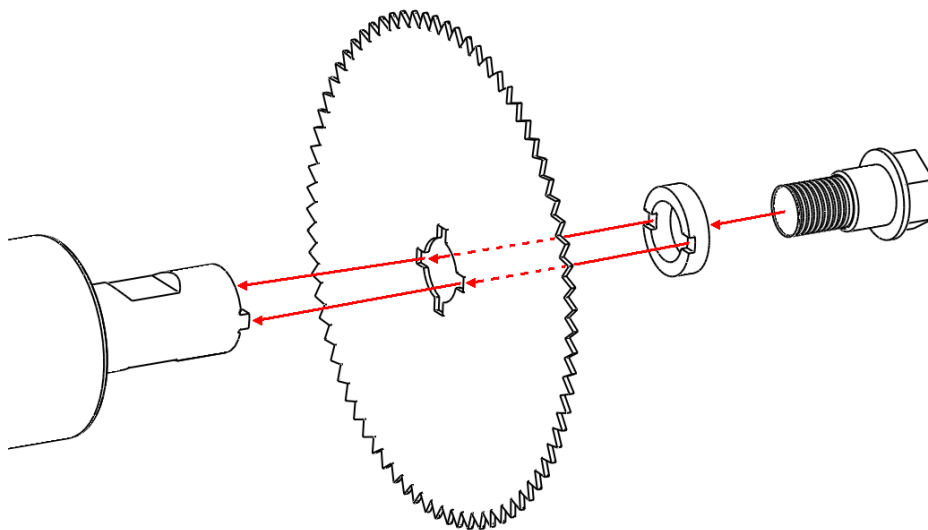

fig. 4 Inserting the saw blade

6 Operation

Switching on and off (see fig. 5)

Switching on: Push the switch forwards (I)

Switching off: Push the switch back (0)

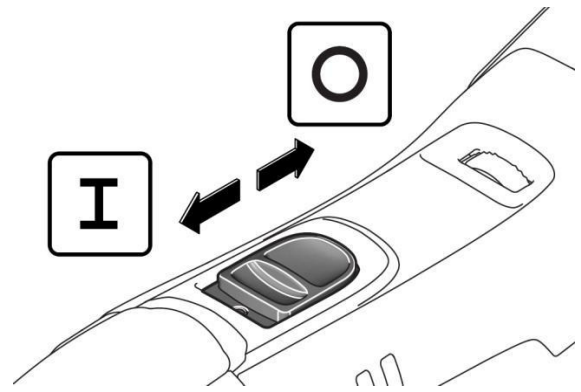

fig. 5 Switching on and off

Setting the oscillating frequency (see fig. 6)

Select the oscillating frequency when the motor is running. The optimum oscillating frequency can be selected at the speed gauge depending on the properties of the plaster cast.

Oscillating frequency preselection using the electronic speed gauge.

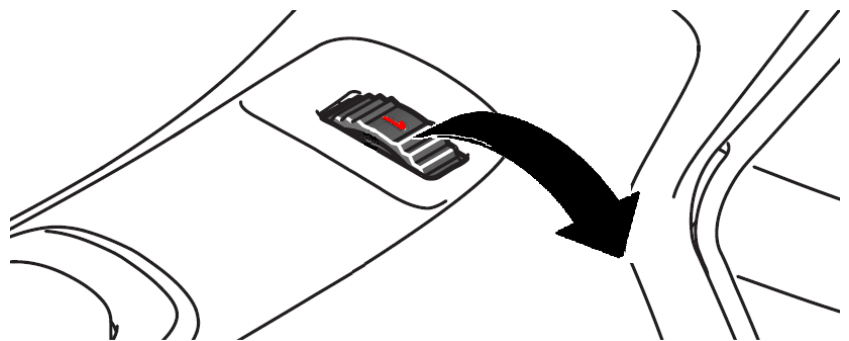

fig. 6 Setting the oscillating frequency

Lowest oscillating frequency (1)

Highest oscillating frequency (6)

6.1 Opening plaster casts

First select a suitable saw blade.

Apply the HEBU oscillating saw with the saw blade mounted to the cast you wish to open and press in lightly. Your guiding hand can be used as a support and for depth control, and to prevent sudden penetration of the blade when the cast has been cut through.

As long as the saw blade is cutting through the plaster, you will be able to feel a resistance. Once the plaster cast has been cut through, this resistance disappears. Once the breakthrough point is tangible, lift the saw blade off lightly without removing it from the cutting groove and move it forwards appr. 15 mm in the direction of cutting.

Then apply the blade again and proceed as described above until the next piece has been cut through.

In this way, the plaster cast is more safely opened through a series of cuts and linear movements along the cutting line than would be the case if executing a continuous linear cut.

After you have used the saw only a few times, you will become accustomed to guiding the saw through the plaster cast and you will also develop an instinctive feel for the moment where no further resistance is tangible and no further pressure should be applied to the saw blade.

If the saw blade oscillates for too long on the wadding, high-speed oscillation can bring about a burning sensation on the skin under the wadding.

Additional remarks:

- Because different materials are used, every plaster or plastic cast has different properties. While working, try to determine the optimum speed for the respective material.
- A lower speed is advantages when cutting through plastic casts. This prevents the plastic from starting to melt due to friction heat generated during cutting.
- Where possible, avoid cutting through plaster casts without wadding when using the HEBU oscillating cast cutting saw. Injuries can result if the skin has become stuck to the plaster, and so does not oscillate with the saw blade. Where a plaster cast close to the skin is preferred, we recommend laying a knitted or felt strip along one side of the arm or leg and drawing a line precisely above this strip on the surface of the plaster cast using indelible ink. When sawing open the cast, this line can be used as guiding mark.
- When applying a plaster cast following surgery, the position of the operation wound should be marked on the surface of the plaster cast. This will allow a window to be cut subsequently in the plaster for removing stitches and observation of the wound.
- Cutting a window in the plaster also simplifies the extraction of bone nails and also facilitates any necessary punctures or incisions.
- Metal rails inserted in the plaster cast should not be cut.
- While serving, check the retaining screw for a firm fit and if necessary tighten.
- Used and blunt saw blades place excessive stress on the motor and should consequently be continuously checked and exchanged in good time.
- To ensure even wear of the saw blade, open the retaining screw and turn the saw blade by 90°.

7 Cleaning and maintenance



**Danger of injury through unintentional activation.
Remove accumulator before cleaning and
maintenance**

The following measures should be performed once a week or more often if the saw is used frequently:

Clean the cooling slots to ensure sufficient ventilation for cooling the motor.

Clean the motor compartment from the outside with a jet of dry compressed air.

Wipe disinfection is suitable for motor housing, accumulator and all accessories, such as saw blades and an open-end wrench. For this purpose, we recommend products with a pH-value within 9-10, e.g. MediClean forte from Dr. Weigert.

It is important to ensure that the disinfecting liquid does not enter the interior of the motor.

8 Accessories

HB 8876	Accumulator 5000 Amp/h
HB 8899-02	Transportation case with insert
HB 8889-01	Retrofit kit (vacuum cleaner, hose, suction unit, tool), 220-240V, 50/60Hz
HB 8889-01V	Retrofit kit (vacuum cleaner, hose, suction unit, tool), 100-120V, 50/60Hz
HB 8879V	Quick Recharger 110V
HB 8879	Quick Recharger 230V
HB 8878-01	Patent Screw
HB 8877	Special grease, 8 g tube
HB 8895-03	Round saw blade TITANIUM, Ø 50 mm
HB 8896-03	Round saw blade, TITANIUM, Ø 65 mm
HB 8895-04	Round saw blade "non-stick", Ø 50 mm
HB 8896-04	Round saw blade, "non-stick", Ø 65 mm
HB 8897-01	Round saw blade, Ø 44 mm, for plaster
HB 8897-02	Round saw blade, Ø 44 mm, x-bite
HB 8895-01	Round saw blade, Ø 50 mm, for plaster
HB 8895-02	Round saw blade, Ø 50 mm, x-bite
HB 8896-01	Round saw blade, Ø 65 mm, for plaster
HB 8896-02	Round saw blade, Ø 65 mm, x-bite
HB 8898-01	Round saw blade, Ø 80 mm, for plaster
HB 8898-02	Round saw blade, Ø 80 mm, x-bite
HB 8893-01	Deep saw blade, Ø 70 mm, for plaster
HB 8893-02	Deep saw blade, Ø 70 mm, x-bite
HB 8892-01	Segmental saw blade, Ø 65 mm, for plaster
HB 8892-02	Segmental saw blade, Ø 65 mm, x-bite
HB 8890-01	Waisted saw blade, Ø 65 mm, for plaster
HB 8890-02	Waisted saw blade, Ø 65 mm, x-bite

9 Spare Parts

E 8894-01	Fork wrench
E 8894-02	Retaining screw
E 8894-03	Fixing ring

10 Servicing

10.1 Saw head

Drawing items refer to fig. 7.

Pos.	Pc.	Description	GOLD II Accu	
			HB 8874	HB 8874V
10	1	Saw head housing	E 8810-00GO	
20	1	main shaft / Fork	E 8810-20/1	
30	1	Front floating bearing	E 8810-12	
40	2	Head Screw with washer	E 8810-13	
50	1	Back floating bearing	E 8810-15/1	
60	1	retaining ring	E 8810-20/2	
70	2	Bearing screw	E 8810-19	

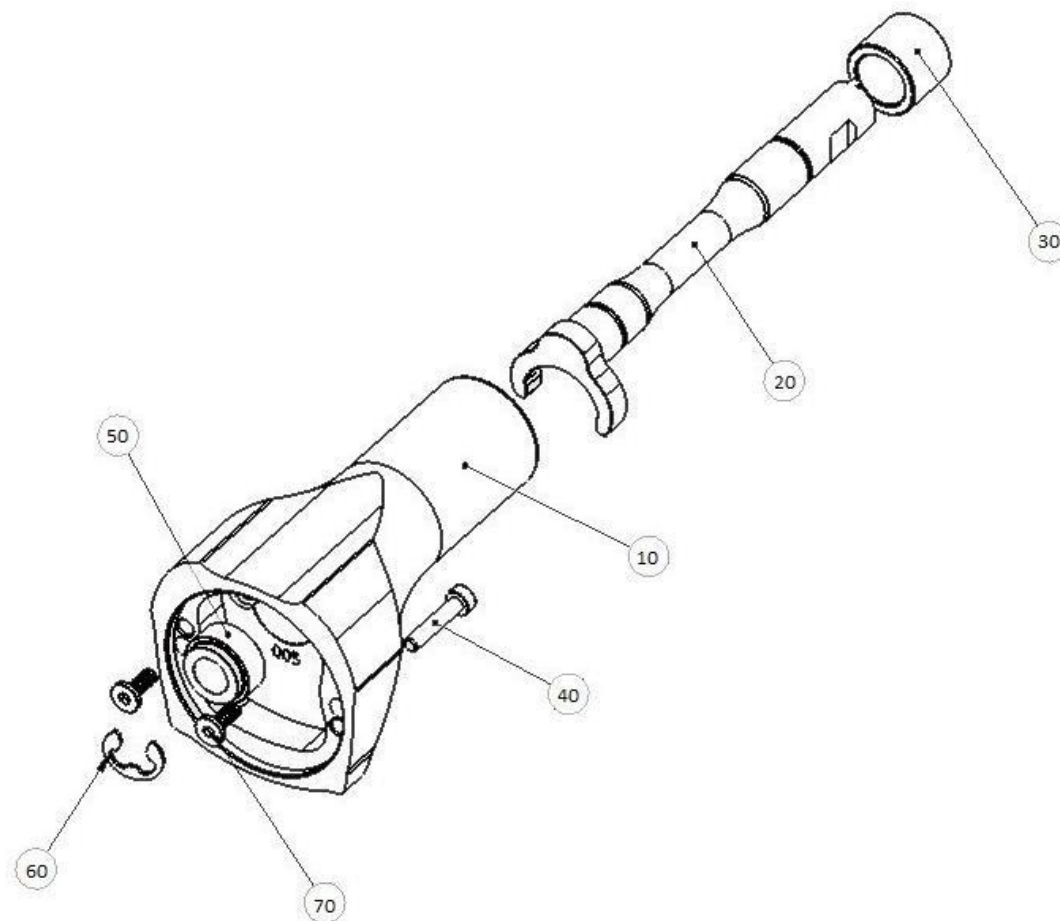

fig. 7 Explosion view of the saw head

10.2 Saw motor

The drawing items refer to fig. 8.

Pos.	Pc.	Description	GOLD II Accu	
			HB 8874	HB 8874V
10	1	Motor housing	E 8831-01	
30	1	Switching slider	E 8831-02	
100	1	Speed controller	E 8831-03	
200	1	Motor	E 8831-04	
240	1	Sealing ring	E 8831-05	
265	1	Motor bearing ring	E 8831-06	
640	5	Screw Tx15 35x16	E 8831-07	
680	1	Hold-down device	E 8831-08	
690	1	Clip	E 8831-09	

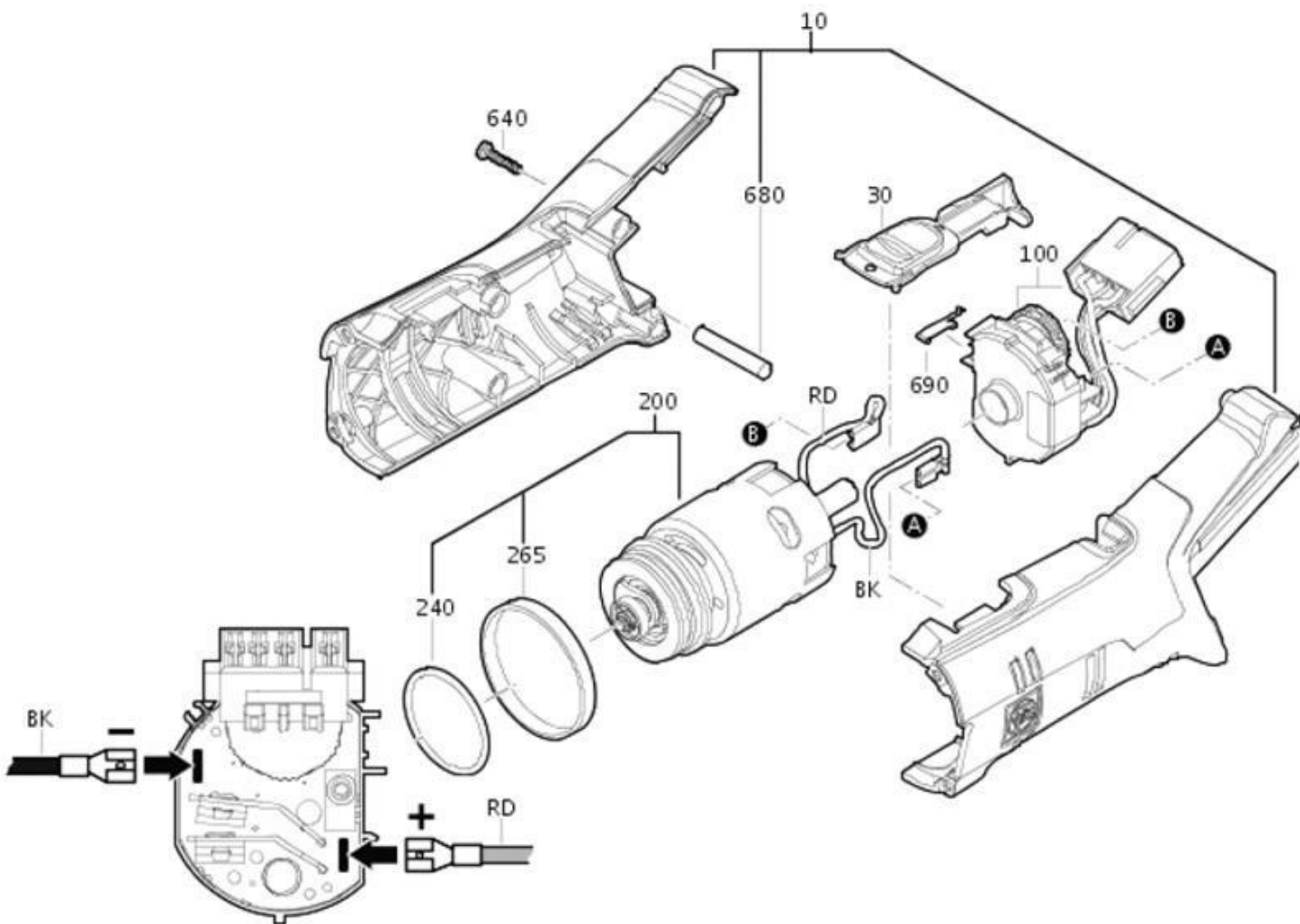

fig. 8

11 Warranty

We provide a guarantee for HEBU cast cutting saws in accordance with statutory and country-specific legislation (proof of purchase by invoice or delivery note). The minimum warranty period is 18 months. In the event of material or production defects, we provide free repair of the device. Any attempt to carry out unauthorized repairs will result in forfeiture of your warranty cover. Damage caused by incorrect handling, overloading or normal wear and tear is not covered by the warranty. Please contact our aftersales service department. In case of warranty claims and repairs, please enclose a copy of the invoice or delivery note with the device.

12 Environmental protection

Any packaging materials, disused devices and accessories must be sent for environmentally friendly recycling or disposal. Electrical devices may not be disposed of with the household waste but taken to the local disposal and recycling facility for electrical devices. For more information on this subject, consult your specialist dealer.



13 Specifications

Model	HB 8874	HB 8874V
Power supply – Charger connector	220-240Volt 50/60Hz	100-120 Volt 50/60Hz
Current type	+ 14,4 DC	
Oscillations	11000-18000 min ⁻¹	
Weight	Accumulator: 680 g	Saw: 1,12kg Total weight: 1,8 kg
Protection class	III 	
IP Code	IP2X	
Noise level (A-graded)	Typically 65-75 dB (A). The noise level during sawing can exceed 85 dB (A). From 85 dB (A), wear ear protectors!	
Hand-arm vibration	Typically lower than 2.5 m/s ² . Measured values determined in accordance with EN 50 144.	

14 Manufacturer and aftersales service address

HEBUmedical GmbH

Badstraße 8
78532 Tuttlingen
Germany

Tel: +49 74 61 / 94 71 - 0
Fax: +49 74 61 / 94 71 - 22

eMail: service@HEBUmedical.de
Web: www.HEBUmedical.de EC-conformity